



KALCO CORPORATION
A Kenneth Avery Lawson Company

LAWSON HERITAGE | *CPS1500*

CONTINUOUS POTTING SYSTEM 1500



FEATURES

- 220V— 1 or 3 Phase
- Variable Speed Filling Conveyor
- Variable Speed Hopper
- Master Control Dial
- 1 to 15 Gallon Pots
- Standard Dust Shield
- Pivoting & Adjustable Rails
- Power Take Off
- Vibrator
- Filling Conveyor with Vibrator / Power Take Off
- 3 Cubic Yard Material Hopper w/ Adj. Gate
- 6ft Return Conveyor
- 10ft. Return Conveyor
- Remote Control Panel
- Easy Adjust Guide Rails
- Standard Adjustable Legs
- 1 Year Warranty

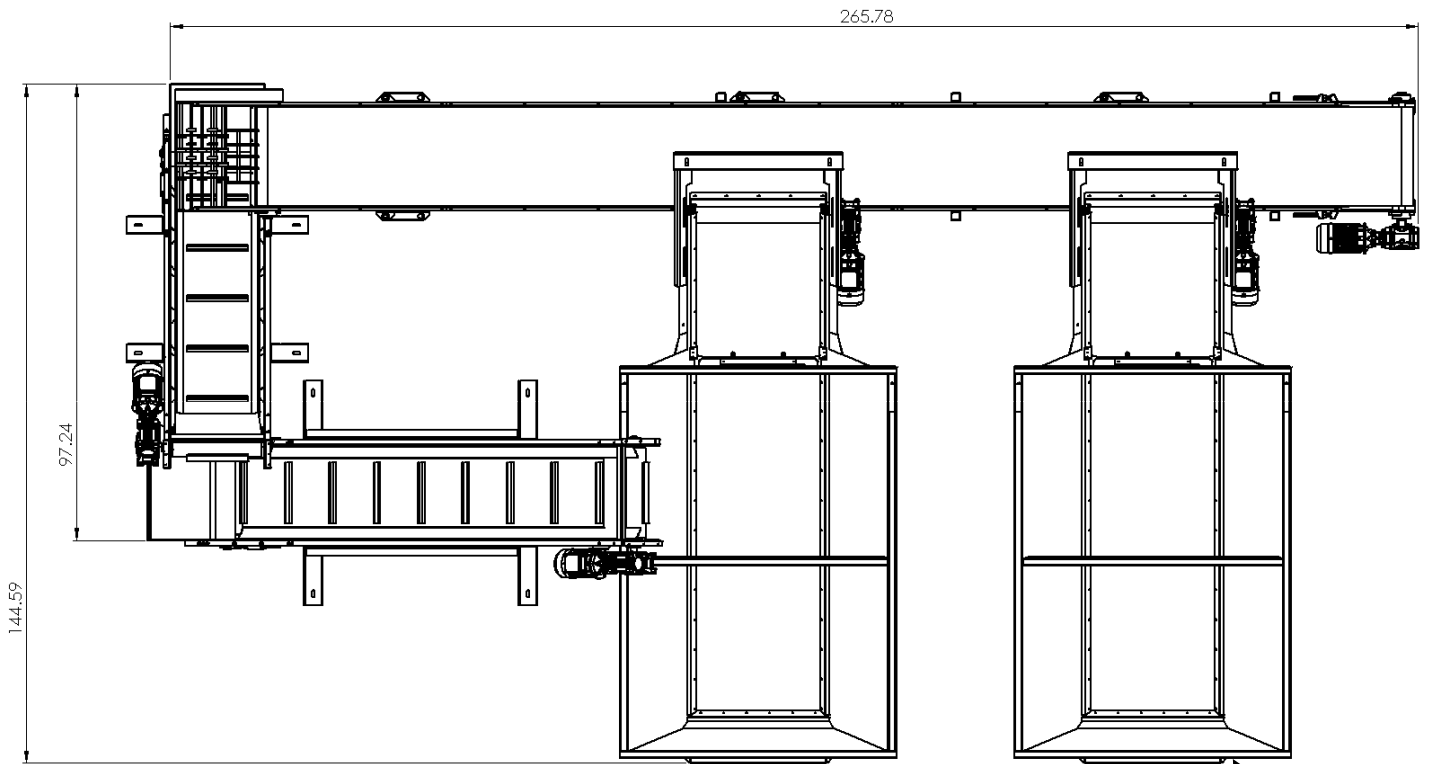

OPTIONAL PRE-FILL HOPPER

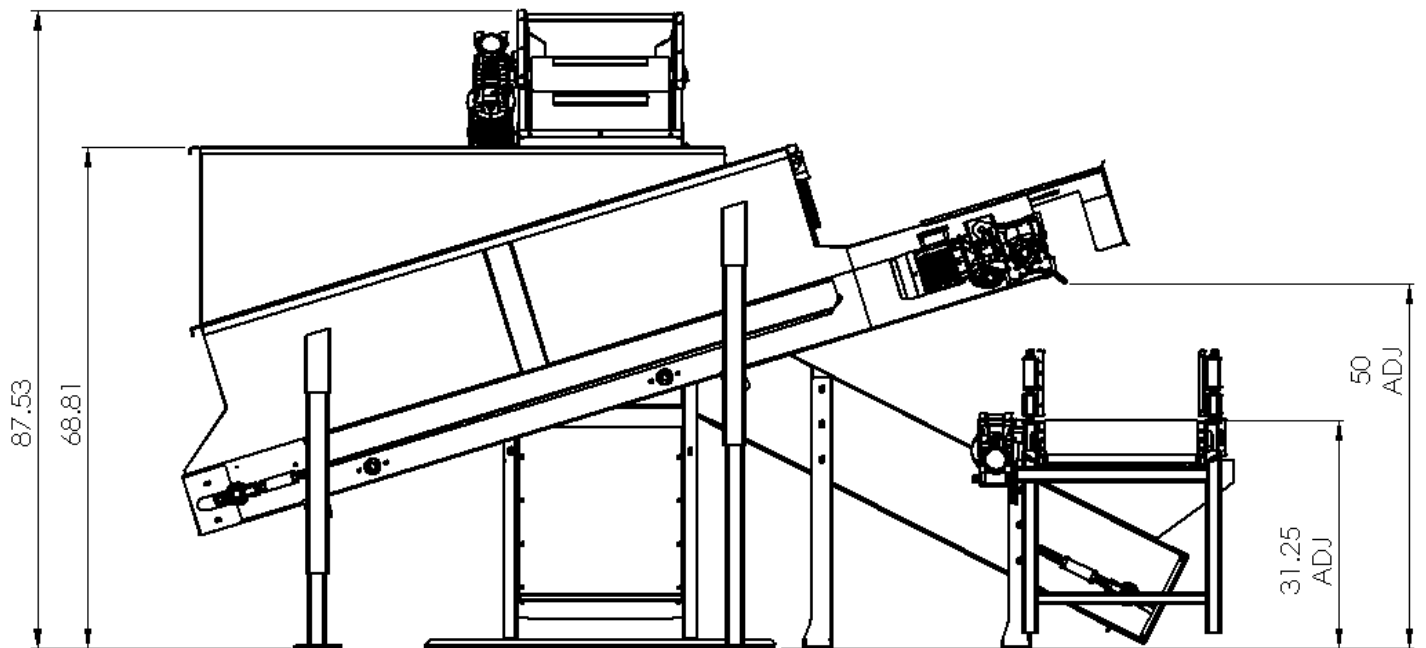

Kalco Corporation
422 Old Nashville Hwy
McMinnville, Tn. 37110
Phone: 931-815-5252
Website: www.kalcocorp.com